

A G E N D A
for

REGULAR COUNCIL MEETING
November 27, 2023

COUNCIL CHAMBERS 7:00 PM

CALL TO ORDER

The Village of Masset acknowledges the un-ceded traditional territory of the Haida Nation on which this meeting is held.

ADOPTION OF AGENDA

COUNCIL MEETING MINUTES

November 6, 2023 Minutes

November 6, 2023 Public Hearing Minutes

MINUTES AND REPORTS OF OTHER ORGANIZATIONS

1. NCRD Board Highlights November 2023

CORRESPONDENCE

C-1 Fisheries and Oceans Langara Point Lightstation

C-2 Minister of Housing

VERBAL REPORTS OF COUNCIL/CAO/CFO

BYLAWS

Bylaw No. 663 To Provide Remuneration to the Council for the Village of Masset

Bylaw No. 664 to Amend Bylaw No 422

NEW BUSINESS

NB-1 MIEDS 3rd Quarter Grants Report

NB-2 Revised Park Drive Lift Station Quote

NB-3 Gwaii Trust Christmas Allocation

PUBLIC QUESTION PERIOD

ADJOURNMENT

Village of Masset Regular Council Meeting of November 6, 2023

Minutes of the Regular Council Meeting held November 6, 2023 in the Council Chambers.

Present:	Mayor:	S. Disney
	Councillors:	T. Carty, B. Johnston, B. Pages
		J. Currie via Zoom
	CAO:	J. Humphries
	CFO:	J. Brown

CALL TO ORDER

The Village of Masset acknowledges the un-ceded traditional territory of the Haida Nation on which this meeting is held.

The meeting was called to order at 7:00 pm.

ADOPTION OF AGENDA

Moved by Councillor Pages, seconded by Councillor Carty to adopt the agenda as presented.

CARRIED

COUNCIL MEETING MINUTES

Council Meeting Minutes October 23, 2023

Moved by Councillor Johnston, seconded by Councillor Carty that the October 23, 2023 Council meeting minutes be adopted as presented.

CARRIED

MINUTES AND REPORTS OF OTHER ORGANIZATIONS

NCRD Board Highlights October 2023

Moved by Councillor Pages, seconded by Councillor Carty that the NCRD October 2023 board report be received and filed.

CARRIED

PETITIONS AND DELEGATES

John Disney

Mr. Disney spoke to Council about his concerns regarding the rise in sea level and the erosion occurring within the Village of Masset, in particular at the end of the airport runway. He has concerns that with the increased frequency of the storms and the higher tides, that the water will reach the end of the runway and start eroding it soon. There is also a concern that the erosion could affect the BC Hydro plant and the recently installed solar farm.

Mr. Disney wanted to ensure that Council was aware of the erosion that was currently happening and that it would worsen as time went on. He suggested that future planning include the possibility of moving the airport to higher ground. Future planning for moving the communities of Masset and Old Massett to higher ground should start happening as well as this will require partnering with other federal and provincial agencies.

Councillor Carty stated that he has also checked out the area at the end of the runway but it is not only the storms and tides eroding the sand dunes, but also the vehicles that drive up and over the dunes that are the problem and suggested that it might be an idea to build some sort of a levy. The Coastal Erosion study was recently reviewed with the public that had projections for the next 100 years. He stated that it is our role to try and take care of the infrastructure and those costs have gone up significantly and that every piece of land is owned by somebody. The cost to move the airport and possibly the communities would be extremely high.

Councillor Pages stated that he lived here most of his life and is aware how the beaches have changed lately. The sand is always moving and forming different patterns. The Village of Masset will work with the various agencies to protect its infrastructure and continue to do our best to ensure it is a livable solution.

Mayor Disney requested that airport staff look at the runway issue. Josh Humphries stated that VOM has a runway rehabilitation application being planned and engineers will be looking at the runway in the very near future.

Moved by Councillor Johnston, seconded by Councillor Carty that Mr. Disney's presentation be received.

CARRIED

VERBAL REPORTS OF COUNCIL/CAO/CFO

Councillor Johnston attended a Gwaii Trust allocation meeting for arts, spoke to the Mayor of Daajing Giids regarding VOYANT.

Councillor Currie reviewed an email from Jennifer Rutt advising she is resigning from MIEDS.

Village of Masset Regular Council Meeting of November 6, 2023

Councillor Carty did not attend any meetings.

Councillor Pages attended a North Coast Regional District meeting.

Mayor Disney attended Coffee and Council in Old Massett, a VIRL executive meeting, a Dixon Entrance Maritime Museum meeting, received the first poppy from the Legion and will take part in Remembrance Day ceremonies in Masset.

Moved by Councillor Carty, seconded by Councillor Pages that the verbal reports be accepted as presented.

CARRIED

BYLAWS

Bylaw No. 663 To Provide Remuneration to the Council for the Village of Masset

Moved by Councillor Pages, seconded by Councillor Carty that Bylaw No. 663 be read a first time.

CARRIED

Moved by Councillor Carty, seconded by Councillor Johnston that Bylaw No. 663 be read a second time.

CARRIED

Moved by Councillor Johnston, seconded by Councillor Carty that Bylaw No. 663 be read a third time.

CARRIED

Bylaw No. 664 to Amend Bylaw No 422

Moved by Councillor Pages, seconded by Councillor Johnston that Bylaw No. 664 be read a third time.

CARRIED

Bylaw No. 665 Water User Rates

Moved by Councillor Johnston, seconded by Councillor Pages that Bylaw No. 665 Water User Rates 5-year format be reconsidered and adopted.

CARRIED

Bylaw No. 666 Sewer User Rates

Moved by Councillor Carty, seconded by Councillor Pages that Bylaw No. 666 Sewer User Rates 5-year format be reconsidered and adopted.

CARRIED

NEW BUSINESS

NB-1 VIRL Board Appointments

Moved by Councillor Carty, seconded by Councillor Johnston, that the Village of Masset appoint Mayor Sheri Disney as representative to the Vancouver Island Regional Library Board.

CARRIED

Moved by Councillor Johnston, seconded by Councillor Pages, that the Village of Masset appoint and Councillor Terry Carty as alternate to the Vancouver Island Regional Library Board.

CARRIED

NB-2 SMS Quarterly Report 3rd Quarter

CAO Joshua Humphries reviewed the report provided by WASCO, issues at the airport have been addressed and there is overall improvement.

Moved by Councillor Pages, seconded by Councillor Johnston that the WASCO SMS Quarterly Report 3rd Quarter be received.

CARRIED

NB-3 Haida Gwaii Healthy Communities Society Christmas Dinner

Moved by Councillor Johnston, seconded by Councillor Pages that the Village of Masset donate the use of the Howard Phillips Community Hall for the Haid Gwaii Healthy Communities Society Christmas dinner.

CARRIED

NB-4 Village of Masset Logo

CAO Joshua Humphries reviewed and presented the top six logo designs. The Village of Masset will purchase the rights to some of the logos for merchandise, keep the existing logo as the official one, and revisit changing the logo at a future date.

Village of Masset Regular Council Meeting of November 6, 2023

Moved by Councillor Carty, seconded by Councillor Johnston to approve \$1,000.00 towards logo design purchases.

CARRIED

NB-5 AP Cheque Listing - September 1-30, 2023

Moved by Councillor Johnston, seconded by Councillor Pages that the cheque listing for September 1st to September 30th, 2023 be approved.

CARRIED

NB-6 AP Cheque Listing - October 1-31, 2023

Moved by Councillor Johnston, seconded by Councillor Carty that the cheque listing for October 1st to October 31st, 2023 be approved.

CARRIED

ADJOURNMENT TO CLOSED SESSION

Moved by Councillor Johnston, seconded by Councillor Carty the meeting be adjourned at 8:11 pm to a closed session.

CARRIED

Recording Secretary

Mayor

Certified Correct, Administrator

Minutes of Public Hearing for Rezoning Application for 1760 Hodges Avenue, Roll #1600000, Lot A, District Lot 7, Land District 46 Plan PRP41930, PID 023-996-846, from GMDC-1 to Residential 3 (R-3)

**Held in Council Chambers
November 6, 2023 6:30 pm**

Present:

Mayor
Councillors

CAO
CFO

Sheri Disney
B. Pages, B. Johnston, T.
Carty, J. Currie
J. Humphries
J. Brown

CALL TO ORDER

The Village of Masset acknowledges the un-ceded traditional territory of the Haida Nation on which this meeting is held.

The meeting was called to order at 6:30 pm.

OPENING REMARKS

Mayor Disney read a statement of purpose for the public meeting regarding the application by the Greater Massett Development Corporation to rezone 1760 Hodges Avenue from GMDC-1 to Residential 3 (R3). All participants were assured that they would have an opportunity to make a presentation about the application only and were asked to clearly state their name and address before commencing their remarks. Mayor Disney also indicated that Council members were there to listen to concerns only, not debate the issue nor make a decision at this time.

APPLICANT PRESENTATION

Saving House Society – Monica Brown

Monica Brown gave a brief summary what is being planned for the property. The plan originally started out as a housing complex for seniors but has been changed to include between 50 to 70 units that will provide accommodation for seniors, families and individuals. They are in the preliminary stages of the project and are working with architects to ensure they meet BC Housing standards.

WRITTEN COMMENTS

The Mayor then asked the CAO to read the written submissions that had been received. All written submissions were received by email as follows:

November 03, 2023, Harold Mackay, 2032 Hemlock Crescent, Masset BC, V0T 1M0 (see attached)

PUBLIC COMMENTS

Michelle Lemire, 1292 McBride Street, Masset BC

Was this property zoned commercial to start?

Mayor Disney replied that the property was originally zoned GMDC 1.

Councillor Carty stated that the Memorandum of Understanding lays out the division of properties the Village of Masset and Old Massett will receive when GMDC is dissolved.

Gary Saunders, 1810 Alder Crescent, Masset BC

Owns property on Trumpeter Drive & Alder Crescent as well as a building in the commercial area of GMDC and was concerned about the trees in the area. It would be nice if there was a buffer of trees left. There are huge Sitka trees close to the Nature Center. Why wasn't the property across from the old hospital site looked at?

Mayor Disney stated that there are some park projects planned for that area in the next one to two years.

Peter Hamel, 1696 Hodges Avenue, Masset BC

Would like some of the trees protected and there are some trails in that area that need to be repaired. Some of the trees are huge and get a fair amount of interest in them.

Margo Hearne, 1696 Hodges Avenue, Masset BC

Delkatla Road does not have a right of way? Would like to see the trails remain and there are nesting birds in some of that area. Masset needs affordable housing but need to be conscious about wildlife and nature.

Josh Humphries confirmed that it does have a right of way.

Monica Brown stated that all of the Board members of the Safe Housing Society are from Old Massett. They have been working on this project for the last 7-8 years and are aware of the issues and concerns for the wildlife and trees in that area.

ADJOURNMENT

Councillor Johnston adjourned the public meeting at 6:56 pm.

Board Highlights

November 2023

Delegations:

The Ministry of Transportation and Infrastructure provided an update on the Ministry's Skeena winter maintenance program. The Chair of the Board thanked the Ministry for their delegation.

The Invasive Species Council of BC and the Department of Fisheries and Oceans Canada provided an update on European green crab programs in B.C. The Chair of the Board thanked the Invasive Species Council of BC and the Department of Fisheries and Oceans Canada for their delegation.

Board Business:

1. The Board resolved to provide a letter of support to the Village of Daajing Giids for its Foundry Centre project.
2. The Board resolved to write a letter to the Minister of Housing to request that properties within electoral areas be included in the Secondary Suite Incentive Program.
3. The Board resolved to support an application to Northern Development Initiative Trust for a grant of up to \$20,000 for a Business Façade Improvement program.
4. The Board resolved to support approval of a residential subdivision.
5. The Board resolved to send a letter to the Canadian Radio-television and Telecommunications Commission in support of Citywest's subsea fibre redundancy project and requesting a timely decision be made on the funding application.
6. The Board appointed Director Evan Putterill as Trustee and Director Johanne Young as Alternate to the Vancouver Island Regional Library Board.

For complete details of NCRD Board meetings, the Agenda and Minutes are posted online at www.ncrdbc.com.

Lianne Trepanier

From: cao@masset.ca
Sent: November 6, 2023 11:24 AM
To: 'Lianne Trepanier'
Subject: FW: Langara Point Lightstation - Workshop Building Replacement Bulletin
Attachments: LANG_WRK_Bulletin_2023-11-06.pdf

Please add this to the next Council meeting.
thanks

Joshua Humphries
Chief Administrative Officer
Village of Masset | Box 68, Masset BC, V0T 1M0
T: 250.626.3995 | F: 250.626.3968 | email: cao@masset.ca

Wings. Waves. Wilderness – www.massetbc.com

From: Laidlaw, Josie (she, her / elle) (DFO/MPO) <Josie.Laidlaw@dfo-mpo.gc.ca>
Sent: November 6, 2023 10:17 AM
To: cao@masset.ca
Cc: Gray, Eliza (she, her / elle, la) (DFO/MPO) <Eliza.Gray@dfo-mpo.gc.ca>
Subject: Langara Point Lightstation - Workshop Building Replacement Bulletin

CAUTION: This email originated from outside your organization. Exercise caution when opening attachments or on clicking links from unknown senders.

Good morning,

Fisheries and Oceans Canada (DFO) is proposing replacement of the workshop building at Langara Point Lightstation, located in the Haida Gwaii archipelago. As the lightstation is protected under the Heritage Lighthouse Protection Act (HLP), consultation with local residents (provincial, municipal, and First Nations governing bodies, and the general public) is required prior to project commencement. The attached PDF contains an overview of the proposed project. Please share this document as you see fit, and reach out with any questions, comments or concerns.

Thank you,

Josie Laidlaw, EIT
Junior Project Engineer
Fisheries and Oceans Canada
Real Property, Safety and Security – Technical Support
C: 250-858-3178



Langara Point Lightstation – Workshop Building Replacement Bulletin

November 6, 2023

Langara Point Lightstation is located on the north-west tip of Langara Island, it is the most northern island of the Haida Gwaii archipelago. The nearest community is the Village of Masset, located approximately 40 kilometers to the southeast. Langara Point Lightstation is a designated heritage lighthouse site under the Heritage Lighthouse Protection Act (HLP). There are seven buildings on site that fall under HLP legislation, including the site's Workshop Building which was constructed in 1965. The HLP outlines the following character-defining elements of the Workshop Building that should be respected:

- Respective built forms and proportions;
- Traditional colour schemes consisting of white for the walls and red for the roof and trim; and,
- The contextual relationship to the lighthouse within a lightstation setting.

The Workshop Building is in extremely poor condition due to a number of issues. The sheet metal wall-sheathing and roofing-materials are severely corroded at many spots with sections missing in some locations, allowing for water ingress, and the exterior wood shingle siding found at one wall is decayed with some of the siding crumbling when touched. Neither of these issues can realistically be repaired. Many of the building surfaces also have coatings that contain high levels of lead paint, both on the interior and exterior. At times over the past several years the interior of the building has been exposed to the elements resulting in water pooling and unsafe work-conditions, mostly due to old windows breaking and a garage-door that no longer closes properly and cannot be repaired. The building has been deemed unsafe and currently is not in use.

It is proposed that the existing Workshop Building be demolished, concrete foundation salvaged and reused, and a new Workshop Building with the same footprint and similar shape be reconstructed.

There are several cracks in the existing concrete foundation that require assessment before re-using. Foundation will be inspected and repairs completed if required. The traditional colour schemes and respective forms and proportions will be adhered to in the new building.

As part of the HLP legislation, consultation with local residents (provincial and municipal bodies, First Nations, and the general public) is required before demolition and building replacement can occur. DFO is open to hearing any concerns and answering any questions about the proposed demolition and new building.

Figures 1-4 on the following page show the condition of the Workshop Building.

Please reach out to Josie Laidlaw at Josie.Laidlaw@dfo-mpo.gc.ca or 250-858-3178 for questions, comments, and concerns about the proposed project.

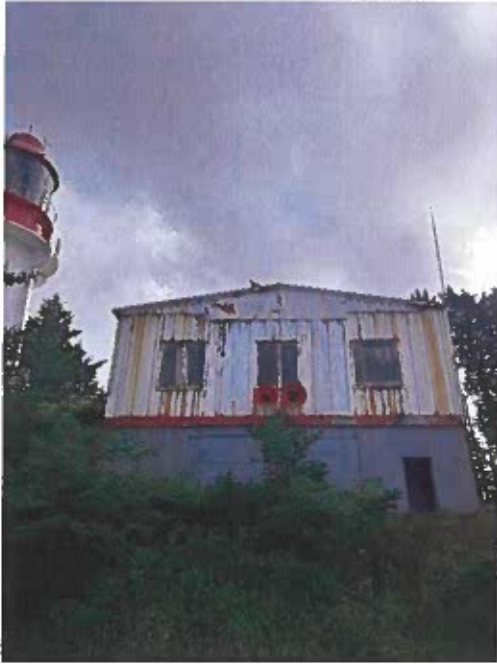

Figure 1: Front View

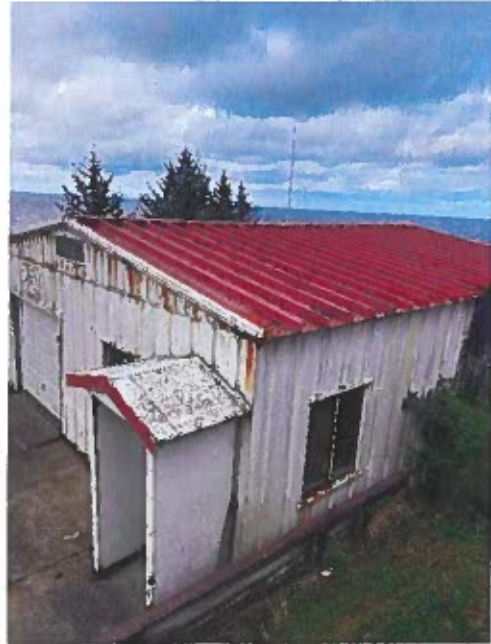

Figure 2: Roof and Entrance View



Figure 3: Siding and Foundation Cracks



Figure 4: Foundation Cracks



BRITISH COLUMBIA

VIA EMAIL

Ref: 62641

November 9, 2023

Their Worship Sheri Disney
Mayor of the Village of Masset
Email: s.disney@gmail.com

Dear Mayor Sheri Disney:

RE: New legislation to support local government housing initiatives

Over the past week, I have introduced several pieces of legislation to support local governments to get more homes built faster while enabling updated and new tools to effectively fund the costs of infrastructure and amenities to support increased housing supply and growth. Taken together, these changes are critical to getting more of the right kind of housing built in the right places to provide homes for British Columbians.

Last week, I introduced Bill 44, to support communities to deliver the homes people need quickly by allowing small-scale multi-unit housing across BC. These homes, including townhomes, triplexes, and secondary suites, can generally be built in a reasonable timeframe and blend more seamlessly into neighbourhoods. The legislation will apply to many areas of the province, and we anticipate it will allow up to 4 units in single-detached and duplex zones (or 3 depending on the size/type of lot) and up to 6 units permitted in single-detached and duplex zones close to bus stops with frequent service. It will also allow secondary suites or an accessory dwelling unit on single-detached lots throughout BC.

Bill 44 will also speed up the approvals process by moving away from spot zoning to ensure more comprehensive upfront planning and zoning to meet current and future housing needs. The changes include using a robust, standard methodology for calculating long-term housing needs for all Housing Needs Reports to ensure consistency across the

.../2

Office of the
Minister of Housing

Website:
www.gov.bc.ca/housing

Mailing Address:
PO Box 9074 Stn Prov Govt
Victoria BC V8W 9E9
Phone: 236 478-3970

Location:
Parliament Buildings
Victoria BC V8V 1X4
Email: HOUS.Minister@gov.bc.ca

province. Municipalities will also be required to update Official Community Plans (OCPs) and zoning bylaws to ensure their communities have sufficient land designated and zoned to meet long-term housing needs and continue to make these updates on a regular basis. The new legislation will also remove the option for local governments to hold public hearings for rezonings for housing projects consistent with OCPs.

Today, I announced new legislation, Bill 47, to support new housing to get built near high-frequency transit, and yesterday Bill 46, to ensure local governments have tools to collect amenity and infrastructure contributions outside of the re-zoning process.

Bill 47 will require local governments to designate areas near high frequency transit stations as 'TOD Areas.' TOD Areas are near SkyTrain stations and busy bus exchanges and are expected to be identified in 29 municipalities in BC. This is different from the 6-unit requirements in the small-scale multi-unit housing legislation which will focus on properties within 400 metres of bus stops with frequent service. TOD areas will include minimum levels of density, size, and dimension prescribed by regulation. Similar to implementing small-scale multi-unit housing requirements, local governments will have a comprehensive provincial policy manual to assist in making bylaw amendments consistent with the TOD legislation. Off-street parking spaces in TOD areas will be determined by the market; local governments will not be able to require off-street residential parking, other than spaces for other uses like commercial, spaces for disabled persons and loading spaces. These changes will help get more of the right kind of housing built in the right places to provide homes for British Columbians. A subsequent letter will notify the identified municipalities in December.

The new legislation will expand the scope of infrastructure for which Development Cost Charges (DCCs) can be collected to include fire protection facilities, police facilities, and solid waste facilities. It also allows local governments to collect DCCs for provincial highway infrastructure projects where there is a cost-sharing arrangement between the municipality and the Province.

The new Amenity Cost Charges (ACCs) tool will allow local governments to collect monetary and in-kind contributions for amenities (e.g., community centres, recreation centres, libraries) to support liveable communities in areas where new housing is going. This tool will provide certainty and transparency for local governments and developers.

Their Worship Sheri Disney
Page 3

We are aware that local governments require tools and supports to facilitate the delivery of affordable housing in their communities. We are currently exploring policy options and additional tools, including the potential for inclusionary zoning, and I look forward to sharing more about this in the coming months.

I know that the new housing initiatives announced over the past week will take work to implement and require additional resources for your local government to meet the requirements. We have committed to \$51 million in funding for local governments to support planning and capacity to meet these new requirements. The funding will be allocated based on population and the volume of work needed because there are different requirements for municipalities and regional governments. The funding will be distributed in early 2024.

The Province has also provided another \$10 million for a second intake of the Local Government Development Approvals Program (LGDAP), managed by the Union of B.C. Municipalities (UBCM). This funding is in addition to the \$1 billion provided to local governments through the Growing Communities Fund to support the delivery of infrastructure projects needed to support increasing density.

The Ministry of Housing is committed to working together and supporting every community as we move forward with new approaches and new ways to deliver the housing supply our province needs. In the coming weeks, we will be providing policy manuals detailing the site-level specifications for small-scale multi-unit housing and TOD areas. Further guidance will be coming in the new year to support implementation of the development finance tools and pro-active zoning requirements. Ministry of Housing staff will be in touch with your administration in the coming weeks to provide more detail about the changes and about funding and educational support and opportunities.

Sincerely,

A handwritten signature in black ink, appearing to read 'Ravi Kahlon', written in a cursive style.

Ravi Kahlon
Minister of Housing

pc: Honourable Rob Fleming, Minister of Transportation and Infrastructure
Honourable Anne Kang, Minister of Municipal Affairs and Housing
Teri Collins, Deputy Minister, Ministry of Housing
Kaye Krishna, Deputy Minister, Ministry of Transportation and Infrastructure
Okenge Yuma Morisho, Deputy Minister, Ministry of Municipal Affairs
Tara Faganello, Assistant Deputy Minister, Ministry of Municipal Affairs
Bindi Sawchuk, Assistant Deputy Minister, Ministry of Housing
Kevin Volk, Assistant Deputy Minister, Ministry of Transportation and Infrastructure
Joshua Humphries, Chief Administrative Officer, Village of Masset (cao@masset.ca)

Links:

Local Government Housing Initiatives Webpage: [Local government housing initiatives - Province of British Columbia](#)

Bill 44 Announcement: news.gov.bc.ca/releases/2023PREM0062-001706

Bill 46 Announcement: news.gov.bc.ca/releases/2023HOUS0063-001737

Bill 47 Announcement: news.gov.bc.ca/releases/2023HOUS0063-001748

VILLAGE OF MASSET

BYLAW NO. 663

**A Bylaw to provide remuneration to the
Council for the Village of Masset.**

WHEREAS, under the provision of the Community Charter, the Council may exercise its authority to establish a bylaw;

NOW THEREFORE, the Council for the Village of Masset in open meeting assembled enacts as follows:

1. There shall be paid out of the Annual Revenue an annual remuneration amount to the Mayor of Fourteen Thousand Dollars (\$14,000.00) and to each of the Councillors Eight Thousand Dollars (\$8000.00).
2. Bylaw No. 639, 2020 is hereby repealed.
3. This bylaw may be cited as "Council Remuneration Bylaw No. 663, 2023".

READ A FIRST TIME THIS 6th DAY OF NOVEMBER 2023.

READ A SECOND TIME THIS 6th DAY OF NOVEMBER 2023.

READ A THIRD TIME THIS 6th DAY OF NOVEMBER 2023.

RECONSIDERED AND ADOPTED THIS 27th DAY OF NOVEMBER 2023.

Clerk

Mayor

Certified a true copy of the "Council
Remuneration Bylaw No. 663, 2023".

Clerk

VILLAGE OF MASSET

BYLAW NO. 664, 2023

A bylaw to amend Zoning Bylaw No. 422

WHEREAS the Village of Masset has received an application to rezone Roll #1600000, Lot A, District Lot 7, Land District 46 Plan PRP41930, PID 023-996-846, 1760 Hodges Avenue; and

WHEREAS the Council for the Village of Masset has deemed it expedient to amend the zoning of Roll #1600000, Lot A, District Lot 7, Land District 46 Plan PRP41930, PID 023-996-846, 1760 Hodges Avenue , from GMDC to Residential 3 (R-3) of Zoning Bylaw No. 422;

NOW THEREFORE the Council for the Village of Masset, in open meeting assembled, enacts as follows;

1. That Roll #1600000, Lot A, District Lot 7, Land District 46 Plan PRP41930, PID 023-996-846, 1760 Hodges Avenue, be rezoned from GMDC to Residential 3 (R-3)
2. This bylaw may be cited as “Zoning Amendment Bylaw No. 664, 2023”.

READ A FIRST TIME THIS 10th DAY OF OCTOBER, 2023

READ A SECOND TIME THIS 10th DAY OF OCTOBER, 2023

PUBLIC HEARING HELD THIS 6th DAY OF NOVEMBER, 2023

READ A THIRD TIME THIS 6th DAY OF NOVEMBER, 2023

RECONSIDERED AND ADOPTED THIS 27th DAY OF NOVEMBER, 2023

Administrator

Mayor

Certified a true copy of the “Zoning Amendment Bylaw No. 664, 2023”

Administrator



Grants report

January to October 2023

3 NOVEMBER 2023

Andrew Hudson, grant writer
Misty Isles Economic Development Society (MIEDS)
andrew@gohaidagwaii.ca

New or upcoming grants

Active Communities Grants

BC Alliance for Healthy Living (Funded by the BC Ministry of Health)

Up to \$50,000

5 February 2024

- Funds programs and small capital projects that improve access to physical activity, sport, and recreation programs in a way that encourages equitable and inclusive access for people from diverse backgrounds
- Eligible applicants include local and Indigenous governments that work with Northern Health or other community partners and measure the project's impact

BC Hydro Community ReGreening Program

BC Hydro

Up to \$7,500 per applicant

7 January 2024

- Funds tree seedlings and other vegetation for streets, parks, and habitat restoration/enhancement — shipping costs are included for some local governments and First Nations, but applicants pay for labour and maintenance
- Trees and other vegetation may be for street or park enhancement, ecosystem restoration or enhancement
- Requires a site planting plan (includes power-line assessment, specific tree species and heights), and permission letters from any affected landowners
- As of 2022, program includes plants for pollinator gardens, plants of cultural significance to Indigenous nations (qualifying plants are at the discretion of the applying Nation, so long as the plants' mature height meets BC Hydro requirements when planted near power lines)
- Preference goes to native B.C. plants

Business Facade Improvement Program

Northern Development Initiative Trust (NDIT)

Up to \$20,000 for grants of up to \$5,000 (matching) for façades, \$500 for wayfinding signs

15 November 2023 (Notice in December for January 1 program starts)

- Annual grant program offers \$20,000 to local governments who then fund \$5,000 matching grants for businesses to improve their commercial building exteriors and \$500 grants for home-based businesses to install wayfinding signage
- Eligible projects include façades, murals, signage, architectural features, lighting, awnings
- Eligible expenses include project labour, contractor fees, equipment rentals, materials/supplies, shipping, design or engineering fees, PST
- Ineligible: Roofs, landscaping, interior improvements, temporary fixtures such as benches, planters, patios, patio heaters, GST, staff wages, permit fees, tools, operating costs, duties
- Note that businesses may now re-apply in future years
- Local governments must submit a final report on the program by January 31 of the following calendar year

Civil Forfeiture Grant Program

Ministry of Public Safety and Solicitor General

Up to \$40,000

4:30 p.m. on 22 November 2023 (Notice in April 2024)

- One-time funding for projects by local governments, non-profits, school districts, health authorities, academic institutions, Indigenous organisations, and police departments (not for individuals)

- Grants available in four streams: crime prevention; restorative justice; Indigenous healing; gender-based violence
- Collaboration letters required from directly involved partners —do not include general letters of support from those not directly involved
- Eligible costs: staffing, honoraria for guest speakers, materials/supplies, resource development, training
- Ineligible costs: Capital costs (including office equipment used beyond project), an expenses inconsistent with public health orders/guidelines regarding COVID-19
- Geographic distribution of funds is considered

Community Tree Grants

Tree Canada

Up to \$10,000 for Greening School Grounds/Edible Trees/Treemendous Communities

3 December 2023 for all three streams (Notice in March)

- Funds tree planting projects 1) on school grounds 2) with fruit- and nut-bearing trees and shrubs 3) in public spaces
- Eligible applicants include schools (for Greening Schools), local/Indigenous governments and non-profits including food banks for Edible Trees and Treemendous Communities
- Eligible expenses include trees and woody shrubs, maintenance materials such as gator bags, multi-year maintenance reserve fund (for three years' pruning/watering, for ex.), site preparation, education materials, shipping, and taxes
- Ineligible expenses include projects on private residential or commercial property, Ash trees or invasive species, removals of large amounts of concrete or modifications to existing infrastructure, hard landscape components such as benches, irrigation (if no trees are planted), paving, administrative costs of more than 15%, parties, food, drink, projects that benefit individuals or businesses, lobbying or advocacy
- Note that Treemendous Communities projects may focus on park and street tree plantings, riparian plantings, invasive species control, stormwater retention, biodiversity corridors and more
- Applicants can apply to multiple streams at once, but are only likely to receive funding for one project
- Preference goes to proposals that satisfy an environmental or social need in a given area and detail how the project will be accomplished. Preference also goes to proposals that consider the long-term health of trees
- Applications require a visual "project landscape plan" that shows site features such as buildings, hard surfaces, pre-existing trees or green space, and the planting area. The plan does not need to be highly technical, complicated, or made with special software
- Funding is distributed as a reimbursement once the planting is done and all supporting documents submitted. If the applicant cannot cover the project expenses, Tree Canada will directly pay suppliers (ex. Nursery, garden centre, etc.)

Complete Communities

Union of B.C. Municipalities (UBCM)

100% funding up to \$150,000 (\$500,000 for regional projects)

12 January 2024 (Notice in 90 days)

- Funds a plan that covers three of the four following topics: 1) housing 2) transportation 3) daily needs 4) infrastructure
- Eligible applicants include local governments and modern Treaty First Nations
- Eligible costs include consultant/contractor fees, honoraria, incremental staff costs, spatial/visual outputs (maps, GIS layers, etc.), translations, culturally appropriate materials
- Ineligible costs include capital costs, implementation, feasibility studies, routine or ongoing planning costs, routine operating costs, monitoring/reporting on implemented actions

- Recipients must report study findings and make an implementation plan within a year
- “Complete communities” meet diverse housing needs; accommodate young and old; and provide a range of job opportunities, amenities and services within a 15-minute walk
- Proposals score higher if they 1) align with complete communities goal 2) show First Nations engagement 2) engage other affected parties 3) show alignment with existing community goals 4) are cost-effective
- With a rationale, UBCM can likely extend 12 June intake deadline to 26 June
- \$10M is available for entire program

Co-op Community Spaces

Federated Co-operatives Limited

\$25,000 to \$150,000 in 100% funding

March 2024 12 pm PST

- Eligible applicants: charities, registered non-profits, community service co-operatives, and non-profits partnered with local government
- Eligible projects: capital projects focused on 1) recreation 2) environmental conservation or 3) urban agriculture
- Project must be done in two years
- Project must include permanent Co-op signage

Disaster Risk Reduction — Climate Adaptation

Union of B.C. Municipalities (UBCM)

Up to \$150,000, 100% funding for Foundational (Risk mapping/assessment, planning)

Up to \$150,000, 100% funding for Non-Structural (Equipment, education, land-use plans)

Up to \$2 million, 100% funding for Small-Scale Structural (ex. flood protection)

18 March 2024

- Funds projects by local governments and First Nations that reduce the risk of natural disasters and climate risks
- Regional projects with multiple grant recipients are encouraged
- Some projects require a qualified professional as project manager
- Eligible Foundational Activities include risk mapping (ex. tsunami/flood); risk assessments (ex. Natural hazards, compounding events, overall community risk profile); long-term plans that account for climate adaptation under given climate scenarios
- Eligible Non-Structural Activities include equipment purchases (ex. Monitoring and hydrometric equipment), land-use plans (including OCP updates)
- Eligible Small-Scale Structural Activities must be financially sustainable, based on planning, and follow provincial/federal standards (ex. for dikes and flood-hazard area plans)
- Ineligible costs include seismic microzonation assessments, plans/structures primarily for reducing wildfire risk, major capital building projects or renovations to existing structures except those for cooling centres
- No stacking rules
- Projects must finish two years from grant approval

Enabling Accessibility Fund

Employment and Social Development Canada

Between \$500,000 and \$3 million for Mid-sized Projects

18 December 2023

- Funds projects that make employment or community activities, programs, and services more accessible to people with disabilities
- Eligible applicants include non-for-profit organisations, municipalities, Indigenous organisations, companies with up to 99 full-time employees

- Examples of Mid-Sized Projects include building or expanding program centres for people with disabilities
- Flat rates are used to budget for the most commonly requested project activities (ex. ramps, lifts, accessible playgrounds)

Emergency Operations Centres Equipment & Training

Union of B.C. Municipalities (UBCM)

Up to \$30,000 and 100% funding

23 February 2024 and 23 February 2025 Funding period(s)

- Funds local governments and First Nations to upgrade equipment and run training for Emergency Operation Centres (EOCs)
- Eligible costs include equipment purchases and installation, training courses (including travel, accommodation), incremental staff and consultant costs, honoraria for Indigenous knowledge keepers and equity-denied populations, public information and translation/development of culturally appropriate EOC materials
- Ineligible costs include major capital expenditures and new EOC buildings, vehicles, and emergency preparedness marketing materials, door prizes
- No stacking rules
- Regional applications welcome; sub-applicants cannot also be lead applicants for another project during the same intake
- Must finish within a year

Emergency Support Services

Union of B.C. Municipalities (UBCM)

Up to \$30,000 and 100% funding (single applicant)

29 January 2024 and 31 January 2025

- Funds local governments and First Nations for emergency support services equipment, training, and/or volunteer recruitment/retention projects
- Focused on moving existing ESS programs to electronic registration and reporting
- Regional projects are eligible, and have a higher maximum funding depending on the number of local governments involved
- Eligible costs include modernization equipment (computers, printers, mobile devices etc.); support supplies and equipment (reception-centre kits, generators, storage, trailers for mobile ESS, etc.); training and exercises for ESS responders, ESS recruitment/retention activities (including small gifts for volunteers); and personal protective gear for responders
- Ineligible costs include vehicles, major capital, or training already offered by EMBC's ESS Training program
- Applications must meet a minimum point score to be considered

FireSmart Community Funding & Supports

Union of B.C. Municipalities (UBCM)

Up to \$100,000 per year for up to two years for lower-risk areas (Class 4 to 5)

Up to \$200,000 per year for up to two years for higher-risk areas (Class 1 to 3)

Up to \$45,000 per application for new FireSmart Structure Protection Trailer program

1 November 2024

- Funds local governments and First Nations in two streams to 1) create FireSmart plans and activities that reduce the risk of wildfire in communities and 2) to reduce wildfire risk on Crown land
- Can fund rebates for FireSmart homeowners, fuel-management activities, select wildfire training courses for firefighters (activities are funded for two years), honoraria for Indigenous cultural keepers and cultural protocols
- Projects that include fuel management on Crown land may exceed funding maximum for those fuel-management activities only if the activities are adjacent to community

structures and they extend no more than 1 km away from a structure density class greater than six

- Regional projects involving multiple applicants are encouraged—regional districts can apply for multiple projects across electoral areas
- Risk-reduction measures must be supported by a plan, such as a Community Wildfire Protection Plan (CWPP)
- Applications that involve fuel management activities or a Community Wildfire Protection Plan or Community Wildfire Resiliency Plan must be previewed by a BCWS Wildfire Prevention Officer/Prevention Specialist and/or a FNESS Mitigation Specialist/Liaison
- Projects must be completed within two years after grant approval
- Applicants are strongly encouraged to create a FireSmart position and have that person oversee project activities (will become a requirement in 2024)

Infrastructure Planning Grant

BC Ministry of Municipal Affairs

Up to \$10,000 per project. First \$5,000 is 100% funding, next is 50%

Ongoing until 31 January 2024

- Offers planning grants toward feasibility/technology/location/cost studies of sewer, water, drainage, transportation, or other local government infrastructure
- Eligible applicants include municipalities and regional districts
- Applicants can file multiple applications at once for multiple projects (declined applications remain on file for next funding round)
- Eligible projects include improving water and wastewater systems, waste disposal, public health and safety, environmental protection/enhancement, asset management, sustainable planning/design/management, energy efficiency and greenhouse gas reductions, climate resiliency, demand-side management, ecological services and natural assets, resource recovery (gas capture, heat recovery, wastewater effluent reuse, rainwater harvesting), partnerships and collaborations with other governments and First Nations, renewable energy plans, watershed management plans, liquid waste management plans, climate adaptation plans, infrastructure condition assessments, rainwater recharge studies, urban forest assessments, local flooding assessments, storm surcharge studies, swale/rain garden planning, ecological accounting studies, plans for universal water metering, water audits, water budgets, fish-passage assessments, community-centre technological feasibility studies, service demand studies
- Ineligible costs include those incurred before the application submission, those for privately owned development, routine maintenance/repair, water main or water pipe testing, and projects where main objective is modelling or is GIS-based (a component of an eligible plan can be), administrative overhead, local government staff time, GST
- Requires application, supplementary form, council/board resolution, public health/regularly agency order if applicable, letter of request if applicable

Local Community Accessibility Grant

Social Planning and Research Council of BC (SPARC BC)

Up to \$25,000 per applicant for Stream 1 (Projects) and Stream 2 (Plans)

Ongoing until 31 March 2026

- Funds projects and plans that improve accessibility for people with disabilities
- Eligible projects and plans must address one of the following: 1) built environment 2) education and awareness 3) policies and programs 4) modelling inclusive practices 5) communication and engagement 6) technology
- Eligible applicants include municipalities and regional districts
- Examples for each category include: 1) ramps, elevators, lifts, washrooms, entrances, audio signals, tactile strips 2) anti-bias workshops, training for businesses 3) more accessible parking/housing/building bylaws, legal advice, accessible recreation programs 4) training to change interview processes, including ASL interpretation at

events, auditing workflows, paying for an Accessibility Advisory Committee 5) creating job-task checklists in pictorial form, braille wayfinding signage, ASL training materials, application forms accessible to screen readers, large-font hardcopies, accessible web pages 6) software to enable accessible documents, flashing fire alarms for deaf employees, specialized headsets, communication tablet, laptops for remote work, specialized tools

- For projects \$10,000 or less, grant will be paid 100%; grants over \$10,000 will be paid 80% after conditions document is signed and 20% after final project report is received
- Applications require application form, letter of support from local accessibility committee,
- Note that all local governments are required to establish an accessibility committee, accessibility plan, and a tool for accessibility feedback by 1 September 2023 — preference goes to local governments in compliance

Marketing Initiatives

Northern Development Initiative Trust (NDIT)

Up to \$20,000, up to 50% of project budget

Three annual intakes: January 31, April 30, July 31

- Funds community marketing campaigns — they might aim to attract business, investment, residents, or tourists
- Preference goes to projects that involve multiple communities, direct First Nations participation, direct economic benefits to local governments, and projects with a regional economic impact

Northern Housing Incentive

Northern Development Initiative Trust (NDIT)

Up to \$10,000 per unit to a max of \$200,000

Three annual intakes: January 31, April 30, July 31

- This program offers a subsidy for new, market-based housing — local governments pass the funds to private developers for building new, multi-unit housing
- Development must result in at least four new self-contained dwelling units
- Can be new construction or conversion of a non-residential building
- Renovations to existing housing units aren't eligible
- Project must be shovel-ready (all bylaws, permits in place)
- Construction must be done in two years
- Requires a housing needs assessment report (done in last five years), council resolution, draft copy of the local government's housing incentive program policy
- Preference to projects that meet BC Energy Step Code, wheelchair-accessible, use local contractors, broadly supported, answers a clear need, and are in communities with fewer than 1,000 people that have previously tried to attract new housing developments

Public Notification & Evacuation Route Planning

Union of B.C. Municipalities (UBCM)

Up to \$25,000 in 100% funding

By April 2024, municipalities to be granted access

- Funds local governments and First Nations to set up public emergency notification systems and identify physical routes that can safely evacuate communities during emergencies (includes estimating speed of local hazards, availability of warning systems, methods of evacuation)
- Plans must follow the B.C. [Evacuation Operational Guide](#) (2021)
- The grant cannot pay for capital costs such as road design, or actual evacuations
- Eligible costs include mapping, test exercises, amendments to existing plans, presentations as well as consultant fees, staff and public info costs

- Emergency Management BC scores applications in a technical review — higher scores go to applications that can show, among other things 1) evidence of local hazards, threat levels, and previous evacuations; 2) challenges to evacuation; 3) consideration of large-scale scenarios
- List of 2023 recipients posted [here](#)

Regional Community to Community Program

Union of B.C. Municipalities (UBCM)

Up to \$10,000 and 100% for C2C forums

Up to \$10,000 for 100% funding for agreements, joint plans/strategies/bylaws/policy

December 2023 Notice within 30 days

- Funds Regional C2C Forums, which are 1) forums to increase overall relations between First Nations and local governments, resolve common issues, or advance tangible outcomes 2) develop formal agreements that advance reconciliation and relationship-building 3) jointly review bylaws and/or policies to advance reconciliation
- Forums must build stronger links between elected officials and senior staff, support local reconciliation/UNDRIP/shared-capacity building, or improve coordination approaches to emergency preparation, including climate change and COVID-19
- Forums are not limited to a pair of neighbouring communities — an all-islands forum that includes Haida and civic communities would be eligible.
- Eligible applicants can apply once per intake, and projects must be done within a year
- Suggested topics include reconciliation, emergency management, service planning, economic development, community development, and infrastructure planning
- Ineligible costs include ongoing operating costs, alcohol, travel within communities, software/hardware purchases

Rural Economic Diversification and Infrastructure Program (REDIP)

BC Ministry of Jobs, Economic Recovery and Innovation (JERI)

Up to \$100,000 in 100% funding over two years for Economic Capacity (\$50,000/year)

Up to 80% and \$100,000/\$1M for infrastructure plans/projects under Economic Diversification

Up to \$500,000 in 100% funding for areas with drop in forestry (Forest Impact Transition)

Third intake July to October 2024

- Eligible lead applicants for Economic Capacity and Economic Diversification projects include local and regional governments; non-profit organisations in communities of less than 25,000; and Indigenous communities, organisations, development corporations in communities of less than 2,500
- Eligible lead applicants for Forest Impact Transition projects are local and regional governments, and Indigenous communities
- Examples of Economic Capacity projects include community economic development studies, staff training in economic development, community consultations on economic development, and staff recruitment/retention projects
- Examples of Economic Diversification projects include “soft infrastructure” projects such as feasibility studies, business plans, program designs, service planning, as well as programs/services that improve the workforce, develop business and industry, retain or expand existing businesses
- Economic Diversification projects involving “hard” infrastructure include architecture/engineering/assessment/planning costs as well as building or renovating buildings and other hard infrastructure
- Ineligible costs include regular maintenance, traditional municipal infrastructure (roads, sewers, sidewalks, etc.), and community recreation (skateparks, playgrounds, gyms, recreation centres, libraries, etc.)
- Applicant contributions can include up to 10% in-kind, such as staff time or use of applicant’s space or equipment
- All projects must finish within two years
- A list of 2022-23 projects funded by the first intake is [available here](#)

Rural, remote and Indigenous food action grants

Northern Health Authority

Up to \$50,000

1 December 2023

- Funds projects that work towards food security or Indigenous food sovereignty
- Eligible applicants include First Nations bands and health centres, Indigenous organisations, non-profits, service agencies, public/private schools, local governments
- Eligible expenses include leadership/advocacy to advance food security, revitalising Indigenous food practices/systems, food security knowledge/transfer/promotion/awareness, support for community capacity to deliver food security programs/services; monitoring and evaluation of food-security programs, boosting community participation to strengthen Indigenous food sovereignty
- Preference goes to projects that improve people's agency, social justice, and sustainability
- Ineligible expenses include large-scale food aid or charitable food projects (ex. Stocking food banks, food bag programs, soup kitchens), individual or personal businesses, academic research, programs focused solely on nutrition education
- Projects must complete two check-ins and an end-of-project summary
- Any other project funding sources should be confirmed before applying

Rural Transit Solutions Fund

Infrastructure Canada

Up to \$50,000 in 80% funding for planning and design (100% for Indigenous)

Up to \$3M in 80% funding for conventional capital projects (100% for Indigenous)

Up to \$5M in 80% funding for zero-emissions capital projects (100% for Indigenous)

Ongoing

- Funds planning and design studies for rural transit programs, and for capital projects (ex. Vehicles, charging stations, software purchases)
- Eligible applicants include local and Indigenous governments, and non-profits applying on their behalf (partnerships encouraged)
- Not for private companies, although applicants can partner with one
- Can be stacked with provincial grants to provide 100% funding
- Contact RTSF-FSTCR@infc.gc.ca

Vision Zero in Road Safety Grant

BC Ministry of Transportation and Infrastructure

Between \$5,000 and \$20,000 for 1) Road improvements or 2) Indigenous projects

18 January 2024

- Funds permanent or temporary pilot projects that improve safety for vulnerable road users (walkers, cyclists, scooters, etc.)
- Eligible applicants include local governments, Indigenous governments, and NGOs such as school districts, parent advisory councils, road-safety groups, charities, etc.
- Example projects include raised crosswalks, solar-powered speeding signs, flashing beacons, innovative pavement markings, curb extensions, bollards
- Eligible costs include engineering
- Ineligible costs include projects on roads or right of ways managed by the Ministry of Transportation and Infrastructure (MOTI)
- Preference for local and Indigenous governments, and to NGOs working with them
- Projects are more likely to receive larger funding amounts if they benefit a large number of people, at least one partnership with additional financial contributions has been secured, and there is a strong implementation and evacuation plan with evidence the applicant has the expertise required
- Not for ongoing operating expenses, cash prizes, purchase of alcohol or other drugs, profit-making activities

Grants list

For a regularly updated list of Haida Gwaii grant options, [please bookmark this link](#).

Questions?

Email andrew@gohaidagwaii.ca or phone 250-626-9150.

Grant applications to October 31

Masset

Date	Applicant	Project	Funder	Program	Request \$	Awarded \$	Status
4-Jan-2023	Village of Masset	Masset Recreation Centre Renovation	BC Ministry of Jobs, Economic Recovery and Innovation	Rural Economic Diversification and Infrastructure Program (REDIP)	\$ 741,305	\$ -	Declined
12-Jan-2023	Village of Masset	Summer jobs program	Employment and Social Development Canada	Canada Summer Jobs	\$ 24,190		Pending
1-Mar-2023	Village of Masset	Masset Covered Plaza	Gwaii Trust Society	Major Contributions	\$ 250,000	\$ 104,885	Approved
1-Mar-2023	Haida Gwaii Fitness Association	HGFA Equipment Upgrade Phase II	Gwaii Trust Society	Major Contributions	\$ 57,379	\$ -	Declined
1-Mar-2023	Dixon Entrance Maritime Museum	Windows and Doors Replacement	Gwaii Trust Society	Major Contributions	\$ 67,115	\$ 67,115	Approved
23-Mar-2023	Village of Masset	Towed Runway Sweeper	Transport Canada	Airports Capital Assistance Program	\$ 491,500		Pending
31-Mar-2023	Village of Masset	Emergency Operations Centre Development Project	Union of B.C. Municipalities	Emergency Operations Centre and Training Program	\$ 29,772		Pending
31-Mar-2023	Village of Masset	2023 Village of Masset Economic Development Capacity Building	Northern Development Initiative Trust	Economic Development Capacity Building	\$ 50,000		Pending
12-May-2023	Village of Masset	Harbour Day 2023	Gwaii Trust Society	Community Events	\$ 6,000	\$ 6,000	Approved
26-May-2023	Village of Masset	Masset Skatepark and Pump Track Design	Gwaii Trust Society	Community Innovation	\$ 10,000	\$ 10,000	Approved
12-Jul-2023	Village of Masset	Masset Skatepark and Pump Track Design	BC Ministry of Municipal Affairs	Infrastructure Planning Grant	\$ 10,000	\$ 10,000	Approved

1-Sept-2023	Village of Masset	MVFD Road Rescue Upgrade	Northern Savings Credit Union	INSPIRE Fund	\$ 45,477	\$ 5,000	Approved
19 October 2023	Village of Masset	2024 MVFD Breathing Equipment Upgrade	Union of B.C. Municipalities	Volunteer and Composite Fire Departments Equipment and Training	\$ 30,000		Pending
26 Oct 2023	Village of Masset	Village of Masset Active Transportation Network Plan	B.C. Ministry of Transportation and Infrastructure	B.C. Active Transportation Infrastructure Grants	\$ 34,994		Pending
30 Oct 2023	Village of Masset	Masset Seaplane Terminal and Delkatla Spit Improvement Project	BC Ministry of Jobs, Economic Recovery and Innovation	Rural Economic Diversification and Infrastructure Program (REDIP)	\$ 997,584		Pending
31 Oct 2023	Village of Masset	Outdoor Benches and Bicycle Racks	Northern Health Authority	IMAGINE	\$ 10,000		Pending
Totals to October 31					\$2,845,316	\$306,963	

Port Clements

Date	Applicant	Project	Funder	Program	Request \$	Awarded \$	Status
31-Mar-2023	Village of Port Clements	2023 Village of Port Clements Economic Development Capacity Building	Northern Development Initiative Trust	Economic Development Capacity Building	\$ 50,000	\$ 50,000	Approved
1-Apr-2023	Village of Port Clements	2023 Port Clements Youth Program	Gwaii Trust Society	Youth-Centred Communities	\$ 10,000	\$ 10,000	Approved
20-Oct-2023	Village of Port Clements	2024 PCVFD Equipment Upgrade	Union of B.C. Municipalities	Volunteer and Composite Fire Departments Equipment and Training	\$ 29,443		Pending
30-Oct-2023	Village of Port Clements	Port Clements Boat Launch Upgrade Plan	BC Ministry of Jobs, Economic Recovery and Innovation	Rural Economic Diversification and Infrastructure Program (REDIP)	\$ 121,505		Pending
1-Nov-2023	Village of Port Clements	2023 Port Clements Winter Holidays	Gwaii Trust Society	Winter Holidays Grant 2023	\$ 8,500		Pending
Totals to October 31					\$219,448	\$60,000	

Daajing Giids

Date	Applicant	Project	Funder	Program	Request \$	Awarded \$	Status
------	-----------	---------	--------	---------	------------	------------	--------

27-Jan-2023	Village of Daajing Giids	ESS Storage and Supplies	Union of B.C. Municipalities	Emergency Support Services	\$ 29,965	\$ 29,965	Approved
15-Feb-2023	Queen Charlotte Heritage Housing Society	IT equipment and training	BC Housing	Housing Provider IT Grant	\$ 3,069		Pending
1-Mar-2023	QCC Fire Prevention Society	Equipment for Daajing Giids Volunteer Firefighters	Gwaii Trust Society	Major Contributions	\$ 42,989	\$ 28,000	Approved
31-Mar-2023	Village of Daajing Giids	2023 Village of Daajing Giids Economic Development Capacity Building	Northern Development Initiative Trust	Economic Development Capacity Building	\$ 50,000	\$ 50,000	Approved
4-Aug-2023	Village of Daajing Giids	2023 Daajing Giids Youth Centre Programs	Rogers Communications	Ted Rogers Community Grant	\$ 10,000		Pending
11-Aug-2023	Village of Daajing Giids	Bear Park Improvements	Northern Development Initiative Trust	Community Places	\$ 52,293	\$ 52,293	Approved
1-Nov-2023	Village of Daajing Giids	Daajing Giids Fire Services Review	Gwaii Trust Society	Community Innovation	\$ 4,920		Pending
Totals to October 31					\$193,237	\$160,258	

North Coast Regional District

Date	Applicant	Project	Funder	Program	Request \$	Awarded \$	Status
20-Jan-2023	North Pacific Cannery National Historic Site	Summer student positions (8)	Employment and Social Development Canada	Young Canada Works	\$ 46,864	\$ 46,864	Approved
3-Mar-2023	Edge of the World Music Festival Society	2023 Edge of the World Music Festival (Performers' fees)	BC Ministry of Tourism, Arts, Culture and Sport	BC Fairs, Festivals and Events Fund	\$ 22,950	-	Declined
31-Mar-2023	North Coast Regional District	2023 North Coast Regional District Economic Development Capacity Building	Northern Development Initiative Trust	Economic Development Capacity Building	\$ 50,000	\$ 50,000	Approved
24-May-2023	Edge of the World Music Festival Society	2023 Edge of the World Music Festival (Performers' fees)	BC Arts Council	Professional Arts Festivals	\$ 25,350		Pending

30-May-2023	Haida Gwaii Recreation Commission Society	Haida Gwaii Adult Cycling Courses	BC Cycling Coalition	2023 Adult Cycling Education Grant	\$ 4,400	\$ 4,400	Approved
8-Jun-2023	Edge of the World Music Festival Society	2023 Edge of the World Music Festival (Workshops)	Northern Development Initiative Trust	Fabulous Festivals and Events	\$ 5,000	\$ -	Declined
21-Jun-2023	ᖃaadáa Gwáay Renewable Energy Cooperative (XGREC)	ᖃaadáa Gwáay Renewable Energy Cooperative Start-up	Grand Challenges Canada	Indigenous Innovation Initiative	\$ 74,956		Pending
25-Oct-2023	North Coast Regional District	Electoral Area D Active Transportation Network Plan	BC Ministry of Transportation and Infrastructure	BC Active Transportation Network Planning Grant	\$ 32,518		Pending
30-Oct-2023	Misty Isles Economic Development Society	MIEDS Comprehensive Review and Five-Year Strategic Plan	BC Ministry of Jobs, Economic Development and Innovation	Rural Economic Diversification and Infrastructure Program (REDIP)	\$ 54,346		Pending
30-Oct-2023	Archipelago Ground Search and Rescue Society	SAR Base and Office Upgrade	Gwaii Trust Society	Community Innovation	\$ 9,743		Pending
31-Oct-2023	Haida Gwaii Recreation Commission Society	Haida Gwaii Seniors Bus	Northern Health Authority	IMAGINE Grants	\$ 6,581		Pending
Totals to October 31					\$332,707	\$101,264	

Village of Masset
Park Drive Lift Station Repairs

TO: Sylvan Daugert
Village of Masset
1686 Main Street
Masset, BC V0T 1M0

The undersigned Bidder, having carefully examined the Contract Documents and locality of the proposed work, and having full knowledge of the work required and the materials to be furnished and used, hereby agrees to provide all necessary materials, supervision, labour and equipment and perform and complete all work, and fulfill everything as set forth and in strict accordance with the Contract Documents and Addenda numbered 1 for the sum of:

Bypass Pumping Price:	² \$ \$104,339.02	\$69,302.90
Pump Base Replacement Price:	² \$ \$69,095.83	\$62,626.77
Contingency Allowance: ³		\$10,000
TOTAL BID: (excluding GST)	² \$ \$183,424.86	\$141,929.67
Goods and Services Tax:	² \$ \$9,171.24	\$7,096.48

- ¹ Bidder to fill in each Addendum No. received, e.g., 1, 2, 3, etc. as applicable.
- ² To be completed by Bidder.
- ³ Payment of the Contingency Allowance or portions thereof will only be made in the event that Changes are implemented as provided for in the General Conditions, in which case the amount of the payment will be determined as specified in the General Conditions. Any unused portion of the Contingency Allowance will be retained by Owner.

The undersigned also agrees:

- 1 that Owner is in no way obligated to accept this bid;
- 2 that Owner may, at Owner's discretion, award to other than the low Bidder;
- 3 that, if the Bid Form is improperly completed or incomplete, Owner shall have the right to disqualify and/or reject this bid;
- 4 that this bid is made without knowledge of the bid prices to be submitted for this work by any other company, firm, or person;
- 5 that this bid is made without any connection or arrangement with any other company, firm, or person submitting a bid for this work;

- 6 that this bid is made without any undisclosed connection or arrangement with any other company, firm, or person having an interest in this bid or in the proposed Contract;
- 7 that this bid is irrevocable for 30 days after the closing date for receipt of bids and that the Owner may, at any time within such period, accept this bid whether any other bid has previously been accepted or not and whether Notice of Award of a contract has been given or not;
- 8 to deposit with Owner a Performance Bond and Labour and Material Payment Bond on the forms provided in these documents and for the amount specified in the General Conditions and the specified insurance endorsement certificates and execute the Contract Agreement in accordance with the time periods specified in the General Conditions, such time periods being extended only on the written approval of Owner;
- 9 to commence and proceed actively with the work promptly following receipt of the Notice to Proceed, and to complete all work under the Contract within the Contract Time subject to the provisions of the General Conditions for extension of Contract Time;
- 10 to commence and proceed actively with the work promptly following receipt of the Notice to Proceed, and to complete all work under the Contract within a period of 90 calendar days from Notice of Award, subject to the provisions of the General Conditions for extension of Contract Time;
- 11 to compensate Owner in accordance with the Contract Documents if the work is not completed within the Contract Time;
- 12 to do all extra work not reasonably inferable from the specifications or drawings, but called for in writing by Engineer and to accept as full compensation therefor payment in accordance with the provisions of the General Conditions;
- 13 that estimates of quantities shown in the Bid Form serve only to provide a basis for comparing bids and that no representations have been made by either Owner or Engineer that the actual quantities will even approximately correspond therewith, and further, that Owner has the right to increase or decrease the quantities in any or all items and to eliminate items entirely from the work;
- 14 that payment for the work done will be made on the basis of the quantities measured by Engineer and at the prices shown in the Bid Form which shall be compensation in full for the work done under the terms of the Contract, exclusive of GST payable by Owner; and
- 15 that payment for the work done will be made at the bid price(s) which shall be compensation in full for the work done under the terms of the Contract, exclusive of GST payable by Owner

SUPPLEMENTS TO BID FORM

The following Supplements to Bid Form are included with and form a part of our Bid. We understand that the information provided on these forms will be used by the Owner during Bid analysis.

00 43 25 - Substitution List

00 45 13 - Bidder's Qualifications

September 2023

Digitally signed by Robert Lee
DN: c=CA, E=robert.lee@tektonltd.ca,
O=Tekton Construction LTD, CN=Robert
Lee
Date: 2023.11.02 08:59:48-0700

Tender

The following Supplements to Bid Form are not being submitted with our bid. These forms will be completed and submitted upon request. We understand that the information provided on these forms may be used by the Owner during bid analysis.

00 43 36 - Subcontract List

This bid is executed under seal at Masset, BC this 1st day of Nov, 2023

Tekton Construction

<u>PO Box 55</u>	<u>Name of Firm</u>
<u>Okanagan Falls, BC, V0H 1R0</u>	<u>Address</u>

For Individual or Partnership:

SIGNED, SEALED AND DELIVERED by:

_____ Bidder (please print)
in the presence of: _____
_____ Name
_____ Address
_____ City/Province/PC
_____ Occupation

_____ Signature
_____ Title

For Limited Company or Corporation:

The Corporate Seal of:

Tekton Construction LTD

_____ Bidder (please print)
was hereunto affixed in the presence of:
Robert Lee

_____ Authorized Signing Officer
Title Principal

_____ Authorized Signing Officer
Title _____

Seal



NOTE: If the bid is by joint venture, add additional forms of execution for each member of the joint venture in the appropriate form or forms as above.

END OF DOCUMENT

Supplement to Bid Form

It is our intention that the following work will, subject to Engineer's approval, be subcontracted to the firms indicated below. All other work will be performed by our own forces, except as authorized in writing by Engineer.

Trade	Name and Address of Subcontractor
Electrician	Brendan Hallihan, Masset BC

END OF DOCUMENT

Supplement to Bid Form

The following is a list of suppliers from whom we intend to purchase various items of material indicated, together with the product brand name or the name of the manufacturer of each.

We will alter neither products nor suppliers from those listed below without the written authorization of the Engineer.

Item	Product Brand Name or Manufacturer	Supplier
Bypass Pumping Equipment	Teral 32TG-61.52 (9) 2	Poco Pump and Blower
Back-up pumps	Powerlist 3/4 HP Grinder Pump (4)	Princess Auto 1.5 HP grinder pump (2)
Vacuum Trailer	Ditch Witch FX-25 500 ft	Sunbelt Rentals
Lay Flat Hoses	4" Black Ribbed (800ft) 3" Black ribbed (200ft)	New Line Hose
Check Valves	N10070-200BR (7) 4	New Line Hose
Alarm System	PreTalk CV3	Barnett
Sewer Plugs 6-10"	050-610 (6) 1	Wolseley
Muni-Ball	Cherne 6-8" (2)	Wolseley

END OF DOCUMENT

Supplement to Bid Form

We provide the following information relative to the Construction Schedule in order that Owner may assess our ability to plan the work and respond to critical deadlines.

Item	Schedule						
	Jan W1	Jan W2	Jan W3	Jan W4	Feb W1	Feb W2	Feb W3
Order/Pick-up Supplies	/						
Mobilize to Site							
Set-up Bypass Equipment					/		
Clean/ Repair Lift Station							/

END OF DOCUMENT

Supplement to Bid Form

We provide the following information in order that Owner may judge our ability to fulfil the Contract requirements.

1. The average number of workers we will employ and maintain on the project is 4.
2. The name of the superintendent we propose to place on the project and their previous experience on this type of construction is as follows:

Superintendent Name: Robert Lee

Project Name and Value (\$)	Owner	Contact Name	Phone Number
Masset WTP Upgrades 3 million	Village of Masset	Paul Turje	604.619.1407
Kimberley PRV Installation 1.4 million	City of Kimberley	Rob Topping	250.432.5681
Tobacco Plains Water Reservoir and Treatment Plant 2.2 million	Tobacco Plains First Nation		250 887-3461
Tunstall Bay Water Reservoir 900,000	Bowen Island Municipality	Patrick Graham	778-871-3589
Ahousaht Residence Renovation 900,000	RCMP - Public Works		250.510.7521
Hiellen & Ocean House Septic Infrastructure Upgrades 1.0 million	Old Masset Village Council	Aaron Mann	778-233-3156

3. The project, owner and contact person for similar sewage pump station work:

Project Name and Value (\$)	Owner	Contact Name	Phone Number
1.0 million	Old Masset Village Council	Aaron Mann	778-233-3156

Village of Masset

Public Works
 1686 Main Street
 Masset, BC V0T 1M0

Cost Savings Proposal for Park Drive Lift Station Repairs Project #: 2023-2784

To Sylvan Daugert and Jonathan Musser

Tekton Construction LTD. Would like to propose alternative procedures for the Park Drive lift station bypass.

Preamble:

The plan outlined in the tender documents instructs contractors to pump out of 2 different manholes. Tekton would like to suggest pumping out of the nearest manhole to the lift station.

Lift Station Isolation Plan:

The plan will consist of 2 muni-balls and 1 traditional sewer plug. The muni-ball and the traditional plug are attached to each other, and both have pressure gauges attached to them.

There will be a 2nd muni-ball inside the lift station entrance pipe with a moisture sensor through the muni-ball to act as a warning in-case the first 2 plugs are leaking. There is EYS sealant to seal around the wire and prevent any potential sewer gas from entering the confined space. Normal confined space procedures, ventilation, and gas monitoring will take place while workers are inside the lift station.

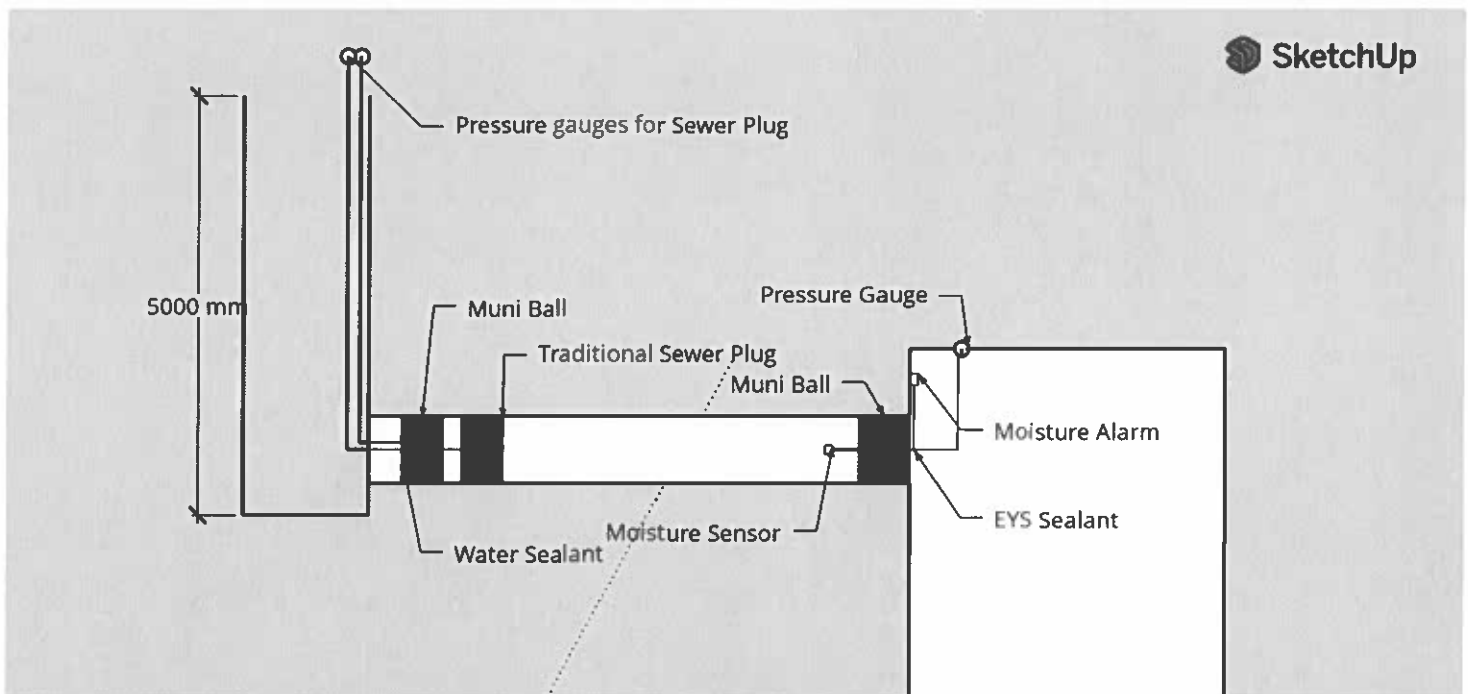

Figure 1: Proposed Lift Station Isolation plan. Product specs attached in.

Pumping Plan:

By pumping out of only 1 manhole we can reduce the amount of pumps, hose, size of generator, and man hours required for set-up and take down.

Tekton plans to use 2x 2inch 2hp grinder pumps and 2x 2inch 1.5hp grinder pumps inside of the plugged manhole. The pumps will be staggered in height and each pump will have it's own float for on/off control. Additionally, there will be a high level alarm float tied into the alarm system in the Park Drive lift station to handle any emergencies.

The pump's 2" discharge will each have their own backflow preventer; the hoses are to be connected to a manifold all connected to 1 common 4" line that leads to the discharge manhole. Instead of keeping an entire spare run (400ft) of 4" hose only 2 extra lengths(100ft) will be kept on hand in case of puncture.

Equipment Data:

1.5HP grinder pump
Max Head: 42.6ft/13m
Flow rate:6340GPH (24000L/H)
Cable:32.8ft/10m
Material: Cast Iron
Weight: 21kg
Voltage: 110V
Amperage: 14A
Hertz: 60Hz

TG SERIES GRINDER PUMP

APPLICATIONS

Designed and built for industrial and commercial sewage application. High Wear Resistance cutting disc and parts to deliver reliable and long lasting performance.

FEATURES

- Powerful High Torque / Continuous Rated Duty Motor
- High Efficiency / Heavy Duty Semi Vortex Impeller
- Double Mechanical Seal
- Powerful Cutting Disc. 18 Slice Arrangements with 54 cuts per revolution.



SPECIFICATIONS

MODEL	32TG-61.5S
Motor (Hp)	2
Voltage (V)	230
Phase	Single
Hertz (Hz)	60
RPM	3450
Full Load Amp @230V	14.5
Discharge Connection	1-1/4"
Std. Cable Length (Ft)	25
Shipping Weight (Lbs)	90

PERFORMANCE

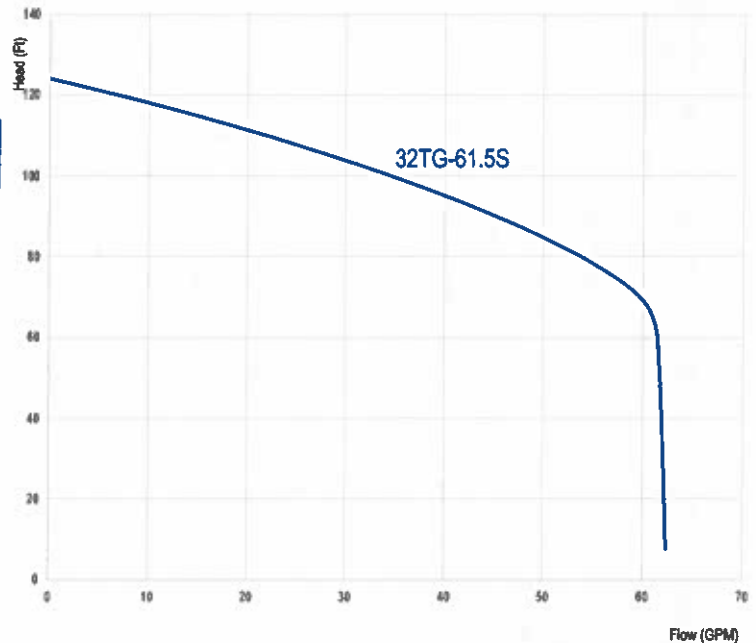

DIMENSIONS

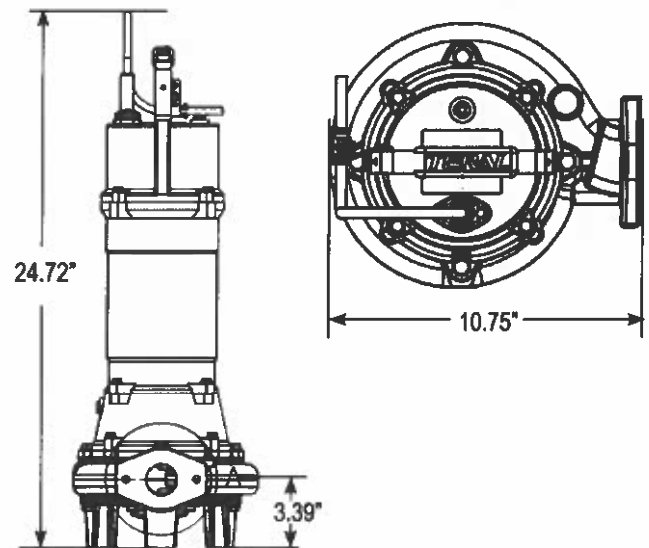

TNSS-2021-04



/ PLUMBING / CHERNE® MULTI-SIZE PLUMBING MUNI-BALL®



Cherne® Multi-Size Plumbing Muni-Ball®

CHERNE® MULTI-SIZE PLUMBING MUNI-BALL®

CHERNE® 6 IN.- 8 IN. MUNI-BALL® PLUG 1-1/2 IN. BYPASS

DETAILS

Cherne® Underground Muni-Ball® Plugs offer a full bypass, allowing both testing and monitoring of piping systems. These plugs are ideal for installation and repair of residential or commercial piping systems. Cherne Industries is a global leader in pipe plugs and testing.

UPC: 675115265066

PART #: 265068

TECHNICAL RESOURCES

[FAQ](#)

[Safety & Instruction Manual](#)

PRODUCTS & SPECS

Part Number	Product Description	Nominal Size	Bypass Diameter	Chain Eye Bolts
<u>265048</u>	Cherne® 4 in.- 6 in. Muni-Ball® Plug 3/4 in. Bypass	4 in. - 6 in. (100 - 150 mm)	3/4 in. F	1/4 in. (1
<u>265068</u>	Cherne® 6 in.- 8 in. Muni-Ball® Plug 1-1/2 in. Bypass	6 in. - 8 in. (150-200 mm)	1 1/2 in. F	3/8 in. (1
<u>265078</u>	Cherne® 8 in.- 10 in. Muni-Ball® Plug 2 in. Bypass	8 in. - 10 in. (200 - 250 mm)	2 in. F	3/8 in. (1

ACCESSORIES & EQUIPMENT

RE: Park Drive Lift Station Repairs

Jonathan Musser <musserj@ae.ca>

Thu 11/9/2023 9:50 AM

To: Koltan Lee <Koltan.Lee@tektonltd.ca>

Cc: Robert Lee <Robert.Lee@tektonltd.ca>; Alan Smith <cao@masset.ca>; VoM PublicWorks <publicworks@masset.ca>

Koltan,

I have reviewed your alternative bypass pumping proposal and it appears to meet the intent of our request. As per the tender documents, the contractor will be responsible for health and safety during the work. The approach you outline here appears adequate for safely completing the work.

Should the price associated with this proposal be acceptable to the Village, this approach is satisfactory to me.

Jonathan Musser, M.A.Sc., P.Eng. (he/him/his)**Associated Engineering (B.C.) Ltd.**

Suite 206 - 1016 McCallum Road, Victoria, BC V9B 4C6

Tel: 250.478.8383 | Cel: 778.223.4911 | Dir: 236.317.2301

GLOBAL PERSPECTIVE
LOCAL FOCUS.Prestige
member

From: Koltan Lee <Koltan.Lee@tektonltd.ca>**Sent:** Wednesday, November 8, 2023 16:04**To:** VoM PublicWorks <publicworks@masset.ca>; Jonathan Musser <musserj@ae.ca>**Cc:** Robert Lee <Robert.Lee@tektonltd.ca>; Alan Smith <cao@masset.ca>**Subject:** Re: Park Drive Lift Station Repairs

Hi Sylvan,

We expect to see an approximate reduction of 40,000\$ from our initial estimate. But we wanted engineers' feedback on our proposal before entering a hard number.

Thanks

-Koltan

From: VoM PublicWorks <publicworks@masset.ca>**Sent:** Wednesday, November 8, 2023 3:59 PM**To:** Koltan Lee <Koltan.Lee@tektonltd.ca>; musserj@ae.ca <musserj@ae.ca>**Cc:** Robert Lee <Robert.Lee@tektonltd.ca>; cao@masset.ca <cao@masset.ca>**Subject:** RE: Park Drive Lift Station Repairs

Thank you,

I do not see a cost adjustment with this submittal? Is that something that you would provide? Or, are you looking for engineering sign-off first?

Sincerely,

sylvan

11/9/23, 10:35 AM

Mail - Koltan Lee - Outlook

From: Koltan Lee [<mailto:Koltan.Lee@tektonltd.ca>]
Sent: Wednesday, November 8, 2023 3:37 PM
To: musserj@ae.ca; publicworks@masset.ca
Cc: Robert Lee <Robert.Lee@tektonltd.ca>
Subject: Park Drive Lift Station Repairs

CAUTION: This email originated from outside your organization. Exercise caution when opening attachments or on clicking links from unknown senders.

Hello Sylvan and Jonathan,

Please see attached Tekton's cost savings proposal.

Best Regards

Koltan Lee, ASCT

Tekton Construction LTD

c 250-488-0063 | w www.tektonltd.ca



You may [unsubscribe from Associated's electronic communications](#) at any time.



VILLAGE OF MASSET

Memo

DATE: November 23, 2023

TO: Josh Humphries, CAO
VOM Mayor and Council

FROM: Jo-Ann Brown, CFO

RE: Gwaii Trust Winter Holidays Funding

Further to my email of November 21, 2023, we will be submitting an application to Gwaii Trust for the Winter Holidays funding before the December 01, 2023 deadline.

In 2022, we were able to combine the Community Events and the Winter Holidays funding that totalled \$16,000.00. This year Gwaii Trust has kept the two programs separate with the Winter Holidays funding allocation being \$12,000.

Attached is the email from Chris Ashurst confirming that Tow Hill residents will be participating in the gift card distribution. Haida Gwaii Consumer's Co-op, Causeway, Fields and Home Hardware have all confirmed that they will participate in the gift card program as well. Also attached is a letter from Toni-Lynn Davidson from Niislaa Naay Healing House Society requesting a donation to the Christmas Tree Party. She has requested a donation of \$1,000.00 but given the reduction of VOM's funding, I am recommending a \$500.00 donation. A couple of our staff members are looking into doing a table at the event and donating some time as well.

We will also be donating \$500.00 to the Masset Senior's for their annual Christmas function.

Winter Holidays Budget Summary

Revenue:	
Gwaii Trust	\$12,000.00
Village of Masset	375.00
Total Revenue	<u>\$12,375.00</u>
Expenses:	
Gift Cards 325 gift cards @ \$35.00	\$ 11,375.00
Masset Seniors	500.00
Donation to Niislaa Nay Christmas Tree Party	500.00
Total Expenses	<u>\$ 12,375.00</u>

I am looking for approval to submit the application to Gwaii Trust with the proposed budget that will include a contribution of \$375.00 from the Village of Masset.

Jo-Ann Brown

From: Chris Ashurst <chris.ashurst@gmail.com>
Sent: November 22, 2023 11:32 AM
To: cfo@masset.ca
Subject: Re: Christmas Gift Cards

CAUTION: This email originated from outside your organization. Exercise caution when opening attachments or on clicking links from unknown senders.

Hi Jo-Ann,

Thanks for reaching out. The Tow Hill Community Association has discussed this and we support and deeply appreciate the Village of Masset once again coordinating gift cards with this year's Xmas allocation from Gwaii Trust for the Tow Hill Community. It's a huge favour.

Thank you again,
Chris

On Tue, Nov 21, 2023 at 11:08 AM <cfo@masset.ca> wrote:

Hi Chris,

We are still planning to do the gift card sign up for Christmas and I am just double checking that Tow Hill residents would like to participate again? The deadline to submit the application is December 1st, 2023 but I will have to bring this to Monday's council meeting for approval.

Jo-Ann Brown

CFO

Village of Masset

Tel: (250) 626-3995 | Fax: (250) 626-3968 | Email: cfo@masset.ca

Wings. Wa Wilderness - www.massetbc.com



Niislaa Naay Healing House Society
P.O.Box 176, Old Massett, HAIDA GWAII V0T 1M0
Tel: 250-626-3911 FAX: 250-626-3357

Josh Humphries

Chief Administrative Officer

November 16, 2021

Thank you for your previous contribution to our last community event. The Community Pumpkin Patch! That event was a huge success. The pumpkins that Village of Massett contributed really made a huge difference in the success of the event.

I am now seeking a monetary donation for the upcoming community Christmas tree party. At this event we buy a Christmas present for every child that signs up, there will be food, and interactive tables, ex: cookie decorating, coloring table, ornament making, photo booth, hot chocolate table and much more. I am looking for a \$1000.00 contribution to this event.

I am hoping to make all these community events that the Old Massett Youth Coordinators put together throughout the year; inclusive of both communities.

Ha'waa, Toni-Lynn Davidson